

SLIDING DOOR TRACK SYSTEM

PER DOOR

FEATURES:

- Super heavy duty - ideal for farm sheds and industrial/commercial applications.
- Two wheel assembly = 300kg per door
Four wheel assembly = 450kg per door.
- Sealed steel wheels with carbon steel ball bearings.
- Zinc plated steel brackets
- Galvanised steel track - pre-punched
- Top mount or wall mount applications
- Optional door stops
- Optional bottom roller guide system
- Suits door thickness of 32mm & above

- OM511** 2 wheel carriage with fixed pin 110 x M12 bolt
- OM512** 4 wheel carriage with fixed pin 110 x M12 bolt
- OM513** 4 wheel carriage with fixed pin 60 x M12 bolt
- OM514** 2 wheel carriage with bracket 60 x M16 bolt
- OM515** 4 wheel carriage with bracket 60 x M16 bolt
- OM521** Suspension bracket with M16 thread
- OM522** Suspension bracket with M12 thread
- OM531** Track wall mounting bracket with bolt
- OM532** Track top mounting bracket with bolt
- OM533** Dual track wall mounting bracket with bolts
- OM534** Track joiner with screws
- OM541** Door stop - optional
- OM551** Brass roller guide - optional
- OM561** Galvanised steel track - 5800mm
- OM571** Galvanised steel guide channel - 5800mm

Wall Mount

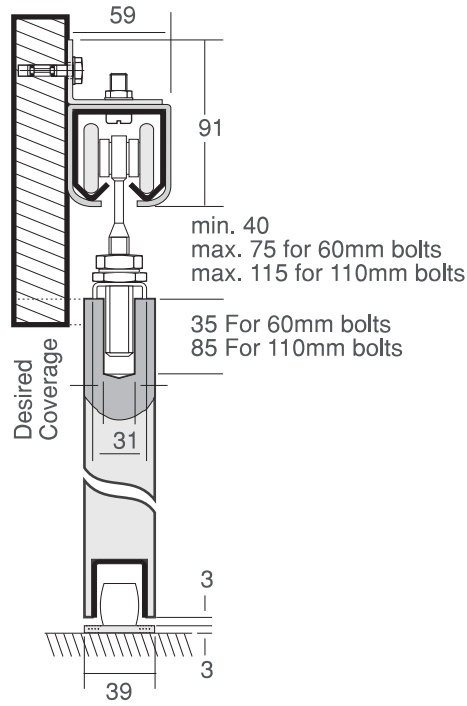

Top Mount

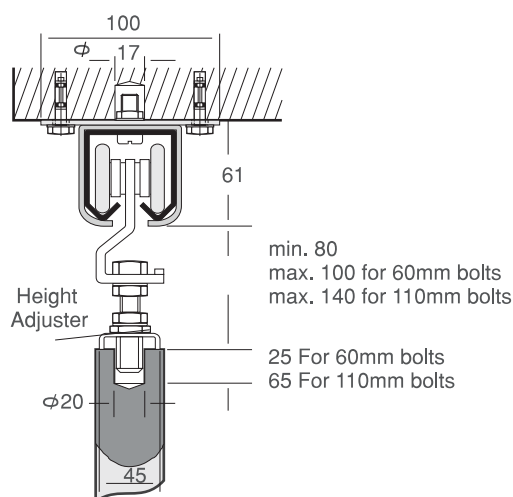

OM531

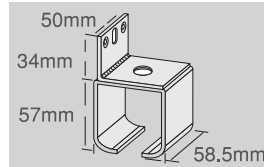

OM532

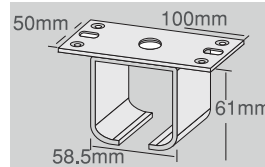

OM533

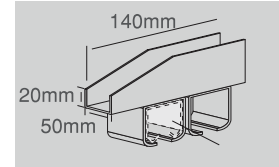

OM561

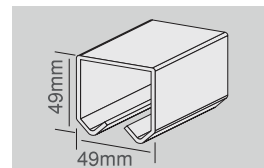

OM511

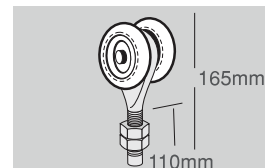

OM534

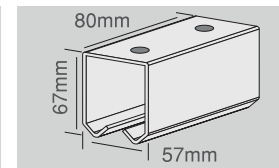

OM514

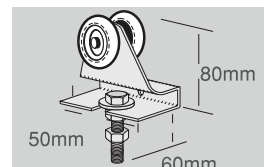

OM512

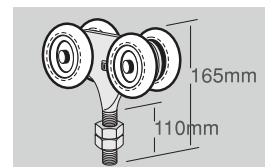

OM513

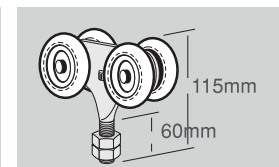

OM521

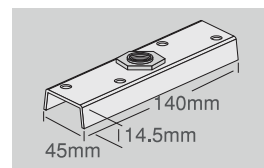

OM522

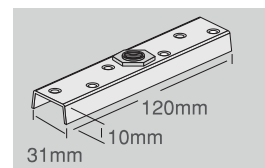

OM541

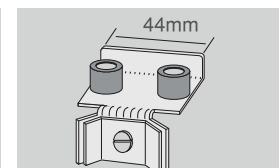

OM515

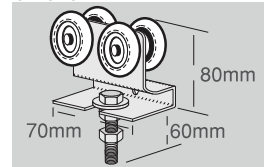

OM551

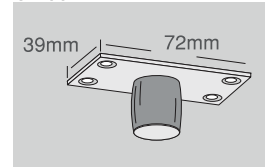

OM571

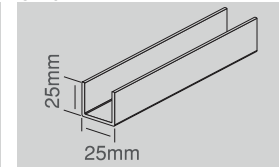

OM515



OM511



COWDROY PRODUCTS LIMITED

Website: www.cowdroy.co.nz

HEAD OFFICE & SHOWROOM
18 Kerwyn Avenue, East Tamaki,
Auckland, New Zealand 2141
Phone: 09 274 7279 Fax: 09 274 4453
Email: sales@cowdroy.co.nz

SOUTH ISLAND OFFICE
56 Treffers Road
Sockburn, Christchurch 8042
Ph: 03 943 2060 Fax: 03 943 2061
Email: chch@cowdroy.co.nz