



Smoothslide Fitting Instructions:

Fig G: Door Fitting step 2.

2) Repeat the process in Step 1 for the front door onto the front track. (Fig G1&2)

Fig G1:

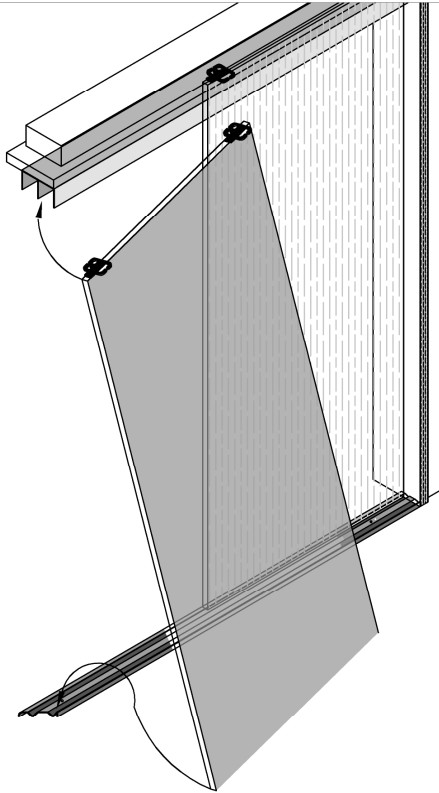

Fig G2:

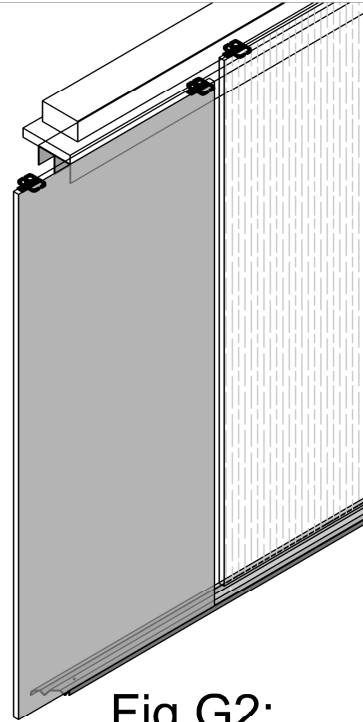
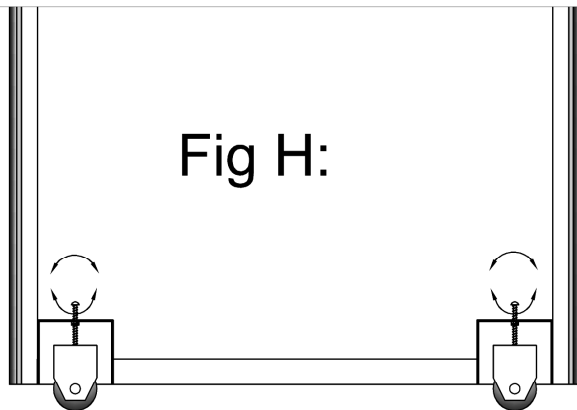

Fig H: Door adjustment.

1) Adjust each door with a screw driver to align the panels to the left and right jambs by turning the adjustment screw on each wheel assembly at the base of each door. (Fig H)

2) Ensure that each track is clean and free from dust or swarf.

Fig H:



Smoothslide Opening Requirements & Measuring Instructions:

Frame Preparation.

1) Determine that your wall framing is square & plumb. Measure in 3 places across the width and height to determine this.

2) Use packers when fitting your jambs (supplied by others), to ensure head & sides are Plumb/Level & Square.
NB: As our Smoothslide units are made to suit your finished opening sizes, this is extremely important.

3) If carpet is being used on the floor, a 9mm packer will be required for the bottom track (supplied on request). If the carpet is existing, you will need to cut a 90mm wide strip out of the carpet for the packer. You will need to arrange a carpet layer to re-fit the carpet back in place.

NB: If the packer is required, our panel height will be adjusted accordingly.

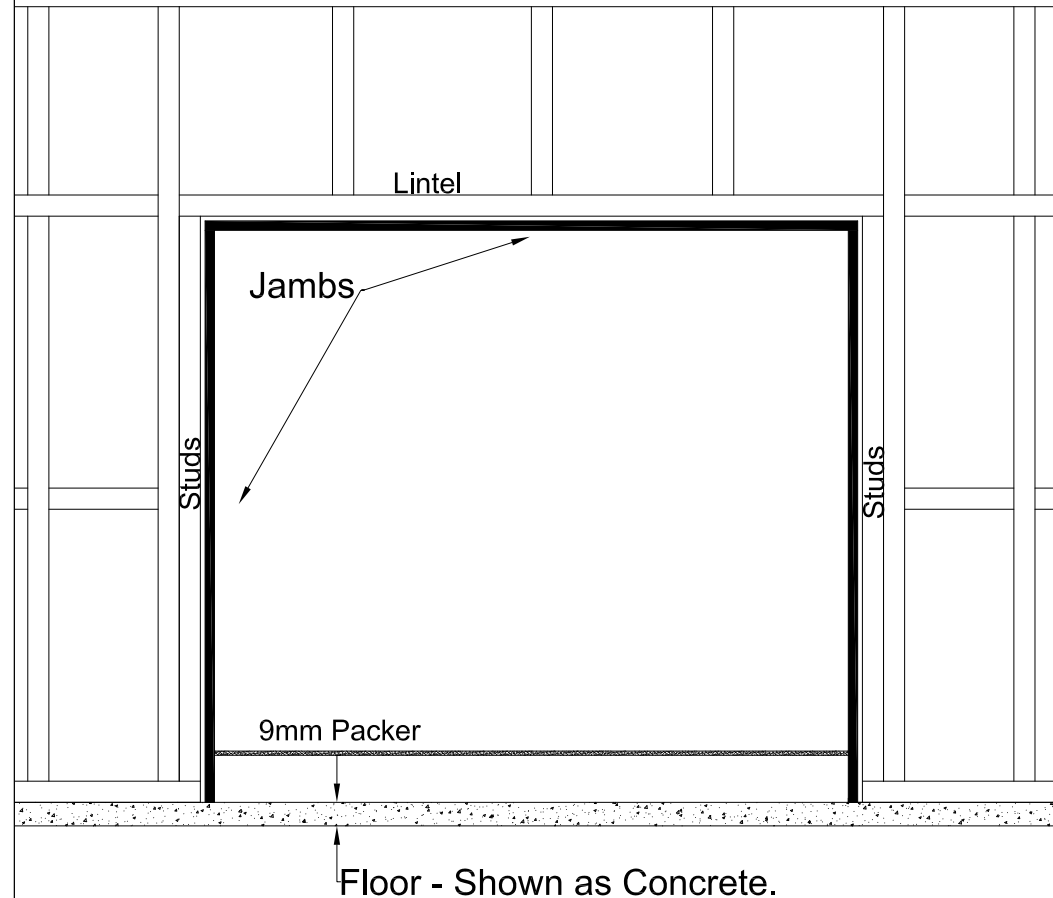



Smoothslide Fitting Instructions:

Fig A: Opening Preparation - If using carpet packer.

- 1) If required, trim the 9mm packer to length so that it fits snug between your finished opening width.
- 2) Glue the supplied 9mm packer to your concrete floor using a good quality builders adhesive or screw/glue to your timber floor. Ensure this is straight and parallel to where the top track will be fitted and flush to front of jamb.

Fig A:

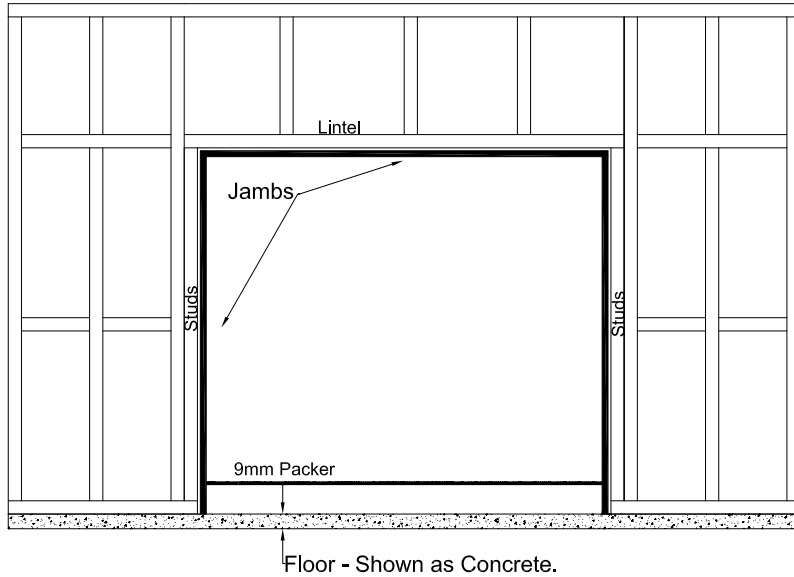

Fig B & C: Fitting of Top & Bottom Tracks - Fitting steps 1 - 3.

- 1) Pre-drill 5mm holes at 600-800mm centres depending on track length & 50mm in from each end through the CENTRE of each Top Track section (Fig B). Remove ALL drilling swarf to prevent guide obstruction.
- 2) Pre-drill 5mm offset holes at 400mm spaces on snap strip, (Fig C). Remove ALL drilling swarf to prevent wheel obstruction.
- 3) Pre-drill corresponding holes in your floor.

Fig B:

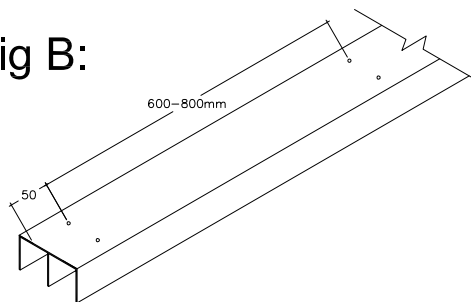
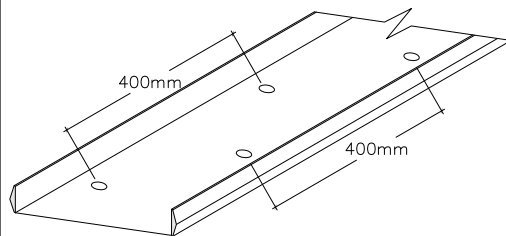

Fig C:



Smoothslide Fitting Instructions:

Fig D & E: Track fitting steps 4, 5 & 6

- 4) Place snap strip on top of packer & screw with supplied 8x12 pozi screws.
- 5) Snap bottom track onto snap strip. (Ensuring front of track is flush with side jambs) (Fig D)
- 6) Screw Top Track in place **making sure it is flush with front of side jambs** (Fig E). Using supplied 8x25 mush head screws.

Fig D:

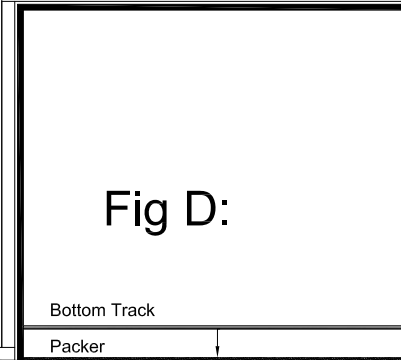

Fig E:

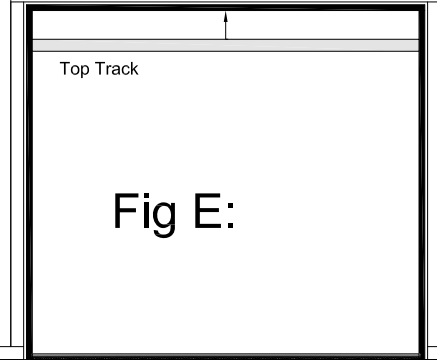

Fig F: Door Fitting steps 1.

- 1) Install the first door up and into the rear channel first by lifting the top of the door into the top guide and then swinging the base of the door onto the bottom track. (Fig F1&2)

Fig F1:

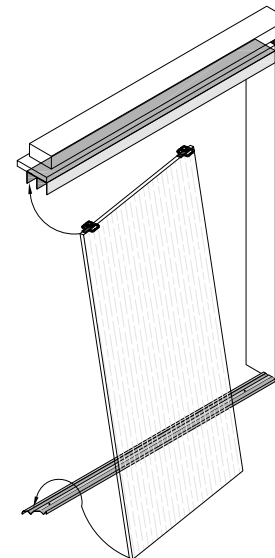

Fig F2:

